

REVISION HISTORY			
REV	DESCRIPTION	DATE	APPROVED

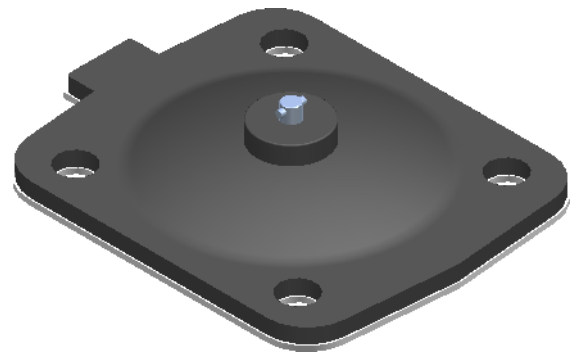

SCALE
1:2

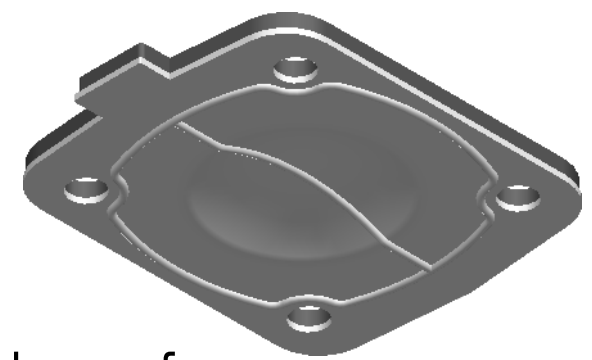

Replacement Diaphragm for :-
OEM PART NUMBER = 2.000-P3
USED ON 2" (DN50) Diaphragm Valve

	NAME	DATE
DRAWN	M. MC KEON	01/12/15
CHECKED		



Material -
FPM BACKING TFM -
DIAPHRAGM
Complies with CFR 177.2600
and Conforms to
USP Class VI Biological Reactivity
Tests Section #87 and #88

TITLE		
DD20-STFM-FPM		
SIZE A	FOOT PRINT DIMENSIONS	REV A
FILE NAME: DD20-STFM-FPM.dft		
SCALE: 1 : 125	ECC:0605	SHEET 1 OF 1

Disclaimer - Diaphragm Direct® does not manufacture, represent, nor sell OEM valves or diaphragms manufactured by any other company. Diaphragm Direct® brand diaphragms are not sponsored by any other manufacturers. Any name, model, part number, brand, image, material or referral is for descriptive purposes only. Diaphragm Direct® brand replacement diaphragms are guaranteed to fit OEM equipment and meet or exceed OEM specifications. Diaphragm Direct® brand replacement diaphragms are covered by the standard Diaphragm Direct® limited product warranty.